

MT I

Calculus

1. From the definition of the derivative,

$$\frac{dy}{dx} = \lim_{\delta x \rightarrow 0} \left\{ \frac{y(x + \delta x) - y(x)}{\delta x} \right\},$$

evaluate $d(x^2)/dx$. In the same way evaluate $d(\sin x)/dx$.

2. Differentiate (i) $y = \sin x e^{x^3}$, (ii) $y = e^{x^3 \sin x}$, (iii) $y = \ln\{\cosh(1/x)\}$.

3. Differentiate (i) $y = x^{\cos x}$, (ii) $y = \log_{10}(x^2)$.

4. Differentiate (i) $y = \cos^{-1} x$, (ii) $y = \tanh^{-1}\{x/(1+x)\}$.

5. (i) Find dy/dx when $ye^{y \ln x} = x^2 + y^2$.

(ii) A particle moves a distance x in time t where $t = ax^2 + bx + c$ with a, b, c constants. Prove that the acceleration is proportional to the cube of the velocity.

6. (i) For $y = \sinh \theta$ and $x = \cosh \theta$, find dy/dx and d^2y/dx^2 .

(ii) For $y = t^m + t^{-m}$ and $x = t + t^{-1}$ show that

$$(x^2 - 4) \left\{ \frac{dy}{dx} \right\}^2 = m^2(y^2 - 4), \quad (x^2 - 4) \frac{d^2y}{dx^2} + x \frac{dy}{dx} - m^2y = 0.$$

7. If x_i is an approximation to a root of the equation $f(x) = 0$, Newton's method of finding a better approximation x_{i+1} is $x_{i+1} = x_i - f(x_i)/f'(x_i)$, where $f'(x) = df/dx$. Explain this method graphically or otherwise in terms of the linear approximation to $f(x)$ near $x = x_i$.

8*. Use Taylor's theorem to show that when h is small

$$(a) f'(a) = \frac{f(a+h) - f(a-h)}{2h} \text{ with an error } O(h^2 f'''(a)).$$

$$(b) f''(a) = \frac{f(a+h) - 2f(a) + f(a-h)}{h^2} \text{ with an error } O(h^2 f''''(a)).$$

Taking $f(x) = \sin x$, $a = \pi/6$, and $h = \pi/180$ find from (a) and (b) the approximate values of $f'(a)$ and $f''(a)$ and compare them to exact values.

These finite-difference formulae are often used to calculate derivatives numerically. How would you construct a more precise finite-difference approximation to $f'(a)$?

Complex numbers

9. For a) $z_1 = 1 + i$, $z_2 = -3 + 2i$ and b) $z_1 = 2e^{i\pi/4}$, $z_2 = e^{-3i\pi/4}$ find
 (i) $z_1 + z_2$, (ii) $z_1 - z_2$, (iii) $z_1 z_2$, (iv) z_1/z_2 , (v) $|z_1|$, (vi) z_1^* .
10. For $z = x + iy$ find the real and imaginary parts of (i) $2 + z$; (ii) z^2 ; z^* ; (iv) $1/z$;
 (v) $|z|$; (vi) i^{-5} ; (vii) $(1 + i)^2$; (viii) $(2 + 3i)/(1 + 6i)$; (ix) $e^{i\pi/6} - e^{-i\pi/6}$.
11. Find the modulus and argument of each of (i) $R + i\omega L$ (ii) $R + i\omega L + 1/i\omega C$ where
 R, L, C are all real.
 Hence find the modulus and argument of each of (iii) $\frac{V_0 e^{i\omega t}}{R + i\omega L}$ (iv) $\frac{V_0 e^{i\omega t}}{R + i\omega L + 1/i\omega C}$
 where V_0 is also real. Find also the real and imaginary parts of (iii) and (iv). (These
 manipulations are important in a.c. circuit theory, where ω is the angular frequency
 and $Z = E + i\omega L + 1/i\omega C$ is the complex impedance of a resistance R , inductance L
 and capacitance C in series.)
12. Change to polar form ($z = re^{i\theta}$)
 (i) $-i$, (ii) $\frac{1}{2} - \frac{\sqrt{3}i}{2}$, (iii) $-3 - 4i$, (iv) $1 + i$, (v) $1 - i$, (vi) $(1 + i)/(1 - i)$.
13. Draw in the complex plane
 (i) $3 - 2i$, (ii) $4e^{-i\pi/6}$, (iii) $|z - 1| = 1$, (iv) $\Re(z^2) = 4$, (v) $z - z^* = 5i$,
 (vi) $z = te^{it}$ (for real values of the parameter t).
14. Find (i) $(1 + 2i)^7$ (ii) $(1 - 2i)^7/(1 + 2i)^7$
15. Solve for all possible values of the real numbers x and y
 (i) $2ix + 3 = y - i$, (ii) $(x + 2y + 3) + i(3x - y - 1) = 0$, (iii) $z^2 = z^{*2}$ ($z = x + iy$),
 (iv) $|2x - 1 + iy| = x^2 + iy$.

MT II

Calculus

1. The function $I(x)$ is defined by $I(x) = \int_a^x f(x')dx'$. Show graphically that $dI(x)/dx = f(x)$.

2. (a) Explain why

$$\frac{dx}{dy} = \left\{ \frac{dy}{dx} \right\}^{-1}.$$

(b) Given that y is a function of x , show, by putting $dy/dx = p$, that

$$\frac{d^2x}{dy^2} = -\frac{d^2y}{dx^2} / \left(\frac{dy}{dx} \right)^3.$$

3. (a) In the differential equation

$$x^2 \frac{d^2y}{dx^2} + (4x + 3x^2) \frac{dy}{dx} + (2 + 6x + 2x^2)y = x$$

replace the dependent variable y by $z = yx^2$ to give

$$\frac{d^2z}{dx^2} + 3 \frac{dz}{dx} + 2z = x.$$

(b) In the differential equation

$$4x \frac{d^2y}{dx^2} + 2(1 - \sqrt{x}) \frac{dy}{dx} - 6y = e^{3\sqrt{x}}$$

replace the independent variable x by $t = \sqrt{x}$ to give

$$\frac{d^2y}{dt^2} - \frac{dy}{dt} - 6y = e^{3t}.$$

(These are equations with constant coefficients that you will soon be able to solve.)

4. Use Leibnitz's theorem to find the 8th derivative of $x^2 \sin x$.

5. Evaluate

$$(i) \int \frac{(x+a) dx}{(1+2ax+x^2)^{3/2}}, \quad (ii) \int_0^{\pi/2} \cos x e^{\sin x} dx, \quad (iii) \int_0^{\pi/2} \cos^3 x dx, \quad (iv) \int_{-2}^2 |x| dx.$$

6. Evaluate

(a) $\int \frac{dx}{(3 + 2x - x^2)^{1/2}}$ (complete square first)

(b) $\int_0^\pi \frac{d\theta}{5 + 3 \cos \theta} = \pi/4$ (use $t = \tan \theta/2$).

7. Evaluate $\int \frac{dx}{x(1+x^2)}$.

8. Evaluate (i) $\int x \sin x \, dx$, (ii) $\int \ln x \, dx$ (write as $\int 1 \cdot \ln x \, dx$).

9. Prove that

$$\int_0^\infty x^n e^{-x^2} \, dx = \frac{1}{2}(n-1) \int_0^\infty x^{n-2} e^{-x^2} \, dx, \quad n \geq 2$$

and hence evaluate $\int_0^\infty x^5 e^{-x^2} \, dx$.

10. By sketching the integrand of the following integrals, determine which integrals vanish:

(i) $\int_{-\infty}^\infty x e^{-x^2} \, dx$, (ii) $\int_{-\pi}^\pi x \sin x \, dx$, (iii) $\int_{-\pi}^\pi x^2 \sin x \, dx$.

11. Prove that if $f(x)$ is an odd function of x , then $\int_{-a}^a f(x) \, dx = 0$.

12. Given that $\ln x$ is defined by $\int_1^x t^{-1} \, dt$, show that $\ln x + \ln y = \ln xy$.

Complex numbers

13. Write the following in the form $a + ib$, where a and b are real:

(i) e^i , (ii) \sqrt{i} , (iii) $\ln i$, (iv) $\cos i$, (v) $\sin i$,

(vi) $\sinh(x + iy)$, (vii) $\ln \frac{1}{2}(\sqrt{3} + i)$, (viii) $(1 + i)^{iy}$.

(Note $i = e^{i\pi/2}$)

14. Sketch the curves C_1 and C_2 in the Argand diagram for z defined respectively by $\arg[(z-4)/(z-1)] = \pi/2$ and $\arg[(z-4)/(z-1)] = 3\pi/2$.

15. Show that

$$\sum_{n=0}^{\infty} 2^{-n} \cos n\theta = \frac{1 - \frac{1}{2} \cos \theta}{\frac{5}{4} - \cos \theta}.$$

16. Prove that

$$\sum_{r=1}^n \binom{n}{r} \sin 2r\theta = 2^n \sin n\theta \cos^n \theta \quad \text{where} \quad \binom{n}{r} \equiv \frac{n!}{(n-r)!r!}.$$

[Hint: express the left side as $\Im \left(e^{in\theta} \sum \binom{n}{r} e^{i(2r-n)\theta} \right)$.]

MT III

Calculus

1. (a) Find the arc length of the curve $y = \cosh x$ between $x = 0$ and $x = 1$.
 (b) Find the arc length of the curve $x = \cos t$, $y = \sin t$ for $0 < t < \pi/2$.
 (c) Find the surface area and volume of a sphere of radius R by treating it as obtained by rotating the curve $y = \sqrt{R^2 - x^2}$ about the x -axis.

For (b) and (c) do you get the answers you expect?

2. Evaluate the following line integrals:

- (a) $\int_C (x^2 + 2y) dx$ from $(0,1)$ to $(2,3)$ where C is the line $y = x + 1$.
 (b) $\int_C xy dx$ from $(0,4)$ to $(4,0)$ where C is the circle $x^2 + y^2 = 16$
 (c) $\int_C (y^2 dx + xy dy + z x dz)$ from $A = (0, 0, 0)$ to $B = (1, 1, 1)$ where (i) C is the straight line from A to B ; (ii) C is the broken line from A to $(0, 0, 1)$ and then from $(0, 1, 1)$ to B .

3. (a) Find a_n and b_n for $\frac{1}{4} - \frac{1}{8} + \frac{1}{16} - \dots = \sum_{n=1}^{\infty} a_n = \sum_{n=0}^{\infty} b_n$. Sum the series.

- (b) Write out the first few terms of the series $\sum_{n=1}^{\infty} \frac{(-1)^n}{n}$.

(c) Squares and products of whole series can also occur, for example $(a_1 + a_2 + a_3 + \dots)^2$ and $(a_1 + a_2 + a_3 + \dots) \times (b_1 + b_2 + b_3 + \dots)$.
 How would you write these in \sum notation?

4. (a) Find by differentiation the expansion of each of the following functions in powers of x up to and including terms in x^3 :

$$(i) e^x, \quad (ii) \sqrt{1+x}, \quad (iii) \tan^{-1} x.$$

(b) Obtain the value of $\sin 31^\circ$ by expanding $\sin x$ to four terms about the point $x = \pi/6$. How accurate is your answer?

5. (a) From the series for $\sin x$ and $\cos x$ show that

$$\tan x = x + \frac{x^3}{3} + \frac{2x^5}{15} + \dots$$

(b) Using the power series for e^y and $\ln(1+x)$, find the first four terms in the series for $\exp\{\ln(1+x)\}$, and comment on the result.

6. Write down the power series expansion for $x^{-1} \sin x$. Hence evaluate, to four significant figures, the integral $\int_0^1 x^{-1} \sin x dx$.

Vectors in 2d

7. Identify which of the following equations make sense mathematically and which do not: (i) $s\mathbf{a} + t\mathbf{b} = u$; (ii) $|s\mathbf{a}| = \mathbf{b}$; (iii) $\mathbf{a} - \mathbf{b} = \mathbf{c}$.
8. Explain, for each of the following statements, whether it is always true, always false, or sometimes true and sometimes false: (i) $|\mathbf{a} + \mathbf{b}| < |\mathbf{a}| + |\mathbf{b}|$; (ii) $|s\mathbf{a}| = s|\mathbf{a}|$; (iii) $(s + t)(\mathbf{a} + \mathbf{b}) = s\mathbf{a} + t\mathbf{b}$
9. The equation $\mathbf{a} \cdot \mathbf{c} = \mathbf{b} \cdot \mathbf{c}$ is satisfied by $\mathbf{a}, \mathbf{b}, \mathbf{c}$. Does this mean that $\mathbf{a} = \mathbf{b}$? For $\mathbf{a} = (1, 1)$ find two different pairs of vectors \mathbf{b}, \mathbf{c} for which $\mathbf{a} \cdot \mathbf{c} = \mathbf{b} \cdot \mathbf{c}$.
10. Explain with the help of a diagram why $\mathbf{a} + (\mathbf{b} + \mathbf{c}) = (\mathbf{a} + \mathbf{b}) + \mathbf{c}$.
11. The straight line L_1 goes through the points $\mathbf{a} = (1, 2)$ and $\mathbf{b} = (0, 1)$. Find the parametric form of this line. Where does the line intersect the x -axis?
12. Calculate the shortest distance of L_1 of problem 11 from the origin. Show that the the line L_1 and the line L_2 which goes through the origin and the point of closest approach of L_1 to the origin are orthogonal to each other.

ODEs

13. Find the 5th roots of unity and plot them on an Argand diagram. What is the sum of the roots?
14. Solve the equation $z^4 = -4i$.
15. Show that the equation with the four roots $z = \frac{1}{2}(\pm\sqrt{3} \pm i)$ is $z^4 - z^2 + 1 = 0$.
16. Show that the equation $(z + i)^n - (z - i)^n = 0$ has roots $z = \cot(r\pi/n)$, where $r = 1, 2, \dots, n - 1$.
17. Find the roots of the equation $(z - 1)^n + (z + 1)^n = 0$. Hence solve the equation $x^3 + 15x^2 + 15x + 1 = 0$.
18. Prove that the sum and product of the roots, x_i , of the polynomial $a_n x^n + \dots + a_0$ satisfy $\sum x_i = -a_{n-1}/a_n$ and $\prod x_i = (-1)^n a_0/a_n$. Hence find the sum and the product of the roots of $P = x^3 - 6x^2 + 11x - 6$. Show that $x = 1$ is a root and by writing $P = (x - 1)Q$, where Q is a quadratic, find the other two roots. Verify that the roots have the expected sum and product.
19. State the order of the following differential equations and whether they are linear or non-linear : (i) $\frac{d^2y}{dx^2} + k^2y = f(x)$; (ii) $\frac{d^2y}{dx^2} + 2y\frac{dy}{dx} = \sin x$; (iii) $\frac{dy}{dx} + y^2 = yx$.

MT IV

Calculus

1. The acceleration of gravity can be found from the length l and period T of a pendulum; the formula is $g = 4\pi^2 l/T^2$. Using the linear approximation, find the relative error in g (i.e. $\Delta g/g$) in the worst case if the relative error in l is 5 % and the relative error in T is 2%.

2. (a) Find du/dt in two ways given that $u = x^n y^n$ and $x = \cos at$, $y = \sin at$, where a, n are constants.

(b) Find du/dx in two ways given that $u = x^2 y + y^{-1}$ and $y = \ln x$.

3. Given that $w = \exp(-x^2 - y^2)$, $x = r \cos \theta$, $y = r \sin \theta$, find $\frac{\partial w}{\partial r}$ and $\frac{\partial w}{\partial \theta}$ in two ways.

4. (a) The perfect gas law $PV = RT$, R is a constant, may be regarded as expressing any one of the quantities pressure P , volume V or temperature T of a perfect gas as a function of the other two. Verify explicitly that

$$\left(\frac{\partial P}{\partial V}\right)_T \left(\frac{\partial V}{\partial T}\right)_P \left(\frac{\partial T}{\partial P}\right)_V = -1 \quad \text{and} \quad \left(\frac{\partial P}{\partial V}\right)_T = 1 / \left(\frac{\partial V}{\partial P}\right)_T.$$

(b) Show that these relations hold whatever the relation $f(P, V, T) = 0$ between P, V and T .

5. Find

$$(i) \lim_{x \rightarrow -1} \frac{\sin \pi x}{1+x}, \quad (ii) \lim_{x \rightarrow \infty} \frac{2x \cos x}{1+x}, \quad (iii) \lim_{x \rightarrow 0} \frac{\sqrt{2+x} - \sqrt{2}}{x},$$

$$(iv) \lim_{x \rightarrow 0} \frac{\sec x - \cos x}{\sin x}, \quad (v) \lim_{x \rightarrow \pi/2} (\sin x)^{\tan x}.$$

6*. A variable z may be expressed either as a function of (u, v) or of (x, y) , where $u = x^2 + y^2$, and $v = 2xy$.

(a) Find $\left(\frac{\partial z}{\partial x}\right)_y$ in terms of $\left(\frac{\partial z}{\partial u}\right)_v$ and $\left(\frac{\partial z}{\partial v}\right)_u$.

(b) Find $\left(\frac{\partial z}{\partial u}\right)_v$ in terms of $\left(\frac{\partial z}{\partial x}\right)_y$ and $\left(\frac{\partial z}{\partial y}\right)_x$.

(c) Express $\left(\frac{\partial z}{\partial u}\right)_v - \left(\frac{\partial z}{\partial v}\right)_u$ in terms of $\left(\frac{\partial z}{\partial x}\right)_y$ and $\left(\frac{\partial z}{\partial y}\right)_x$.

(d) Verify your expression explicitly in the case $z = u + v$.

7*. Sketch the graph of

$$f(x) = e^{-x} + 2x, \quad x \geq 0; \quad f(x) = e^x, \quad x < 0$$

and sketch its 1st, 2nd and 3rd derivatives. Show that the third derivative is discontinuous at $x = 0$.

Vectors & linear equations

8. Solve the linear equation $6x + 2y = 4$ for y and interpret geometrically the implications of the solutions for the vector $\mathbf{r} = (x, y)$.

9. Solve the system of linear equations $x + 3y = 2$ and $2x + 3y = 1$ for $\mathbf{r} = (x, y)$ and give a geometrical interpretation of the solution.

10. Solve the system of linear equations $x + 3y = 2$, $2x + 3y = 1$ and $4x + 9y = 5$ for \mathbf{r} and give a geometrical interpretation of the solution. Can you use the matrix method in this case?

ODEs

11. Solve the following differential equations using the method stated:

(a) **Separable** (i) $\frac{dy}{dx} = xe^y/(1+x^2)$, $y = 0$ at $x = 0$. (ii) $\frac{dx}{dt} = (2tx^2 + t)/t^2x - x$

(b) **Almost separable** $\frac{dy}{dx} = 2(2x + y)^2$

(c) **Homogeneous** $2\frac{dy}{dx} = (xy + y^2)/x^2$

(d) **Homogeneous but for constants** $\frac{dy}{dx} = (x + y - 1)/(x - y - 2)$

(e) **Integrating Factor** (i) $\frac{dy}{dx} + y/x = 3$, $x = 0$ at $y = 0$. (ii) $\frac{dx}{dt} + x \cos t = \sin 2t$

(f) **Bernoulli** $\frac{dy}{dx} + y = xy^{2/3}$.

12. Solve the following first order differential equations :

(i) $\frac{dy}{dx} = \frac{x - y \cos x}{\sin x}$

(ii) $(3x + x^2)\frac{dy}{dx} = 5y - 8$

(iii) $\frac{dy}{dx} + \frac{2x}{y} = 3$

(iv) $\frac{dy}{dx} + y/x = 2x^{3/2}y^{1/2}$

(v) $2\frac{dy}{dx} = \frac{y}{x} + \frac{y^3}{x^3}$

(vi) $xy\frac{dy}{dx} - y^2 = (x + y)^2e^{-y/x}$

(vii) $x(x - 1)\frac{dy}{dx} + y = x(x - 1)^2$

$$(viii) \ 2x \frac{dy}{dx} - y = x^2$$

$$(ix) \ \frac{dx}{dt} = \cos(x+t), \ x = \pi/1 \text{ at } t = 0$$

$$(x) \ \frac{dy}{dx} = \frac{x-y}{x-y+1}$$

$$(xi) \ \frac{dx}{dy} = \cos 2y - x \cot y, \ x = 1/2 \text{ at } y = \pi/2$$

MT V

Calculus

1. Expand $f(x, y) = e^{xy}$ to three terms around the point $x = 2, y = 3$.
2. Find the position and nature of the stationary points of the following functions and sketch rough contour graphs in each case.

$$(i) f(x, y) = x^2 + y^2, \quad (ii) f(x, y) = x^3 + y^3 - 2(x^2 + y^2) + 3xy,$$

$$(iii) f(x, y) = \sin x \sin y \sin(x + y), \quad 0 < x < \pi/2; \quad 0 < y < \pi/2.$$

3. (a) Which of the following are exact differentials? For those that are exact, find f .

$$(i) df = x dy + y dx, \quad (ii) df = x dy - y dx, \quad (iii) df = x dx + y dy + z dz.$$

- (b) What is the value of $\oint x dy + y dx$ around the curve $x^4 + y^4 = 1$?

- 4*. For the function

$$y = \cos(a \cos^{-1} x)$$

show that

$$(1 - x^2)y'' - xy' + a^2y = 0 \tag{1}$$

where a is a constant.

Use Leibnitz' theorem to differentiate (1) n times and then put $x = 0$ to show that for $n \geq 0$

$$y^{(n+2)}(0) = (n^2 - a^2)y^{(n)}(0)$$

where $y^{(n)}(0)$ is the n^{th} derivative of $y(x)$ evaluated at $x = 0$.

Use this result to obtain a terminating power series expansion for $y = \cos(3 \cos^{-1} x)$ in terms of x . Verify that your solution solves (1).

Vectors & linear equations

5. One definition of a vector is that it is a quantity which can be completely specified by a magnitude and a direction. Another definition is that a vector can be completely defined by three numbers, and we most often use Cartesian components as these three numbers. The magnitude of a vector is specified by one number. Discuss how the direction cosines constitute two further numbers (and not three) which specify the direction of the vector.

6. We define three vectors in Cartesian coordinates $\mathbf{a} = (4, 2, -2)$, $\mathbf{b} = (1, -2, 3)$, and $\mathbf{c} = (1, 3, -4)$.

- (i) Find the scalar product $\mathbf{b} \cdot \mathbf{c}$.
- (ii) Calculate the angle α between the vectors \mathbf{a} and \mathbf{b} .
- (iii) Show that the vector $\mathbf{b} + \mathbf{c}$ is parallel to the vector \mathbf{a} .

7*. Circle and line in 2D. A circle centered at the origin with a radius $R = 1$ is intersected by the line L_1 which goes through the points $\mathbf{a} = (1, 2)$ and $\mathbf{b} = (0, 1)$. How long is the piece of the line inside the circle?

8*. The vector $\mathbf{a} = (4, 2)$ is reflected at the line $\mathbf{r} = \lambda \mathbf{n}$ where $\mathbf{n} = (1, 1)/\sqrt{2}$. What are the coordinates of the reflected vector \mathbf{b} ?

ODEs

9. L_1 is the differential operator

$$L_1 = \left(\frac{d}{dx} + 2 \right).$$

Evaluate (i) $L_1 x^2$, (ii) $L_1(xe^{2x})$, (iii) $L_1(xe^{-2x})$.

10. L_2 is the differential operator

$$L_2 = \left(\frac{d}{dx} - 1 \right).$$

Express the operator $L_3 = L_2 L_1$ in terms of $\frac{d^2}{dx^2}$, $\frac{d}{dx}$, etc. Show that $L_1 L_2 = L_2 L_1$.

11. By introducing a new variable $Y = (4y - x)$, or otherwise, show that the solution of the o.d.e.

$$\frac{dy}{dx} - 16y^2 + 8xy = x^2$$

satisfies $4y - x - \frac{1}{2} = A(4y - x + \frac{1}{2})e^{4x}$, where A is an arbitrary constant.

12. Solve the o.d.e.

$$\frac{dy}{dx} = \frac{(3x^2 + 2xy + y^2) \sin x - (6x + 2y) \cos x}{(2x + 2y) \cos x}.$$

[Hint: look for a function $f(x, y)$ whose differential df gives the o.d.e.]

13. The equation

$$\frac{dy}{dx} + ky = y^n \sin x,$$

where k and n are constants, is linear and homogeneous for $n = 1$. State a property of the solutions to this equation for $n = 1$ that is **not** true for $n \neq 1$.

Solve the equation for $n \neq 1$ by making the substitution $z = y^{1-n}$.

14. Find the general solution of

$$\frac{d^2 y}{dx^2} - 4 \frac{dy}{dx} + 3y = 10 \cos x.$$

15. Show that the general solution of

$$\frac{d^2 y}{dx^2} + 2 \frac{dy}{dx} + y = 2e^{-x} + x^3 + 2 \cos x.$$

is $y = (A + Bx + x^2)e^{-x} + \sin x + x^3 - 6x^2 + 18x - 24$, where A, B are arbitrary constants.

MT VI

Vectors & linear equations

1. (i) Give the condition for the vectors \mathbf{a} , \mathbf{b} and \mathbf{c} to lie in one plane.
 (ii) Given that $\mathbf{a} + \mathbf{b} + \mathbf{c} = 0$, prove that $\mathbf{a} \times \mathbf{b} = \mathbf{b} \times \mathbf{c} = \mathbf{c} \times \mathbf{a}$ and discuss the geometrical meaning of these equalities.
2. Prove:
 - (i) $(\mathbf{a} \times \mathbf{b}) \cdot \mathbf{c} = \mathbf{a} \cdot (\mathbf{b} \times \mathbf{c})$;
 - (ii) $(\mathbf{a} \times \mathbf{b}) \times \mathbf{c} = (\mathbf{a} \cdot \mathbf{c})\mathbf{b} - (\mathbf{b} \cdot \mathbf{c})\mathbf{a}$.
3. (i) Evaluate $(\mathbf{a} \times \mathbf{b})^2 + (\mathbf{a} \cdot \mathbf{b})^2$.
 (ii) Given that α_1 (α_2), β_1 (β_2), and γ_1 (γ_2) are the direction cosines of the vector \mathbf{s}_1 (\mathbf{s}_2), give an expression for the angle between \mathbf{s}_1 and \mathbf{s}_2 .
4. Prove $(\mathbf{a} \times \mathbf{b}) \cdot (\mathbf{a} \times \mathbf{c}) = (\mathbf{b} \cdot \mathbf{c})\mathbf{a}^2 - (\mathbf{a} \cdot \mathbf{c})(\mathbf{a} \cdot \mathbf{b})$. Use this relation to find the angle between two faces of a regular tetrahedron.
5. Describe the surfaces or figures represented by (i) $|\mathbf{r} - \mathbf{a}| = |\mathbf{b}|$; (ii) $\mathbf{r} = \mathbf{a} + \lambda\mathbf{b}$; (iii) $(\mathbf{r} - \mathbf{a}) \cdot \mathbf{b} = 0$, where λ is a variable parameter and \mathbf{a} and \mathbf{b} are given constant vectors.
6. If \mathbf{a} , \mathbf{b} and \mathbf{c} are the position vectors of three points, what points are represented by $(p\mathbf{a} + q\mathbf{b})/(p + q)$ and $(p\mathbf{a} + q\mathbf{b} + r\mathbf{c})/(p + q + r)$, where p , q and r are arbitrary scalars?
 A, B, C and D are four arbitrary points. Show that the mid-points of AB, BC, CD and DA form a parallelogram whose diagonals meet in the centroid of the four points A, B, C and D. If the four points A, B, C and D form a regular tetrahedron of side length x , show that the parallelogram is a square and find its area.
7. Solve the following equations for the unknown vector \mathbf{r} and discuss the solutions. (\mathbf{a} , \mathbf{b} , \mathbf{c} and \mathbf{d} are given vectors and k is a scalar.)
 (i) $\mathbf{r} \times \mathbf{a} = \mathbf{b}$; (ii) $\mathbf{r} \cdot \mathbf{c} = k$; (iii) $\mathbf{r} \times \mathbf{a} = \mathbf{b}$ and $\mathbf{r} \cdot \mathbf{c} = k$; (iv) $\mathbf{a} \times \mathbf{r} + \mathbf{b}(\mathbf{c} \cdot \mathbf{r}) = \mathbf{d}$.
8. Resolve the vector \mathbf{r} into two components, one along a given vector \mathbf{a} and one at right angles to \mathbf{a} .
9. A, B and C are the three points $(0, 1, 1)$, $(1, 0, 1)$ and $(1, 2, 1)$. Find the equations of (i) the plane P through A, B and C; (ii) the line L perpendicular to P through Q, where Q lies on AB and $AQ:QB = 2$; (iii) the plane containing L that passes through A.

ODEs

10. Solve the simultaneous differential equations

$$\begin{aligned}\frac{dy}{dx} + 2\frac{dz}{dx} + 4y + 10z - 2 &= 0 \\ \frac{dy}{dx} + \frac{dz}{dx} + y - z + 3 &= 0\end{aligned}$$

where $y = 0$ and $z = -2$ when $x = 0$.

11. Find the solution of

$$\frac{d^2y}{dx^2} - 2\frac{dy}{dx} + y = 3e^x$$

for which $y = 3$ and $\frac{dy}{dx} = 0$ at $x = 0$.

12. The currents i_1 and i_2 in two coupled LC circuits satisfy the equations

$$\begin{aligned}L\frac{d^2i_1}{dt^2} + \frac{i_1}{C} - M\frac{d^2i_2}{dt^2} &= 0 \\ L\frac{d^2i_2}{dt^2} + \frac{i_2}{C} - M\frac{d^2i_1}{dt^2} &= 0,\end{aligned}$$

where $0 < M < L$. Find formulae for the two possible frequencies at which the coupled system may oscillate sinusoidally. [Hint: obtained uncoupled equations by taking the sum and difference of the given equations.]

13. A mass m is constrained to move in a straight line and is attached to a spring of strength $\lambda^2 m$ and a dashpot which produces a retarding force $-\alpha mv$, where v is the velocity of the mass. Find the steady state displacement of the mass when an amplitude-modulated periodic force $Am \cos pt \sin \omega t$ with $p \ll \omega$ and $\alpha \ll \omega$ is applied to it.

Show that for $\omega = \lambda$ the displacement of the amplitude-modulated wave is approximately given by

$$-A \frac{\cos \omega t \sin(pt + \phi)}{\sqrt{4\omega^2 p^2 + \alpha^2 \omega^2}} \quad \text{where} \quad \cos \phi = \frac{2\omega p}{\sqrt{4\omega^2 p^2 + \alpha^2 \omega^2}}.$$

where A is a constant.

14. Solve the differential equations

$$\begin{aligned}2\frac{d^2y}{dx^2} - 3\frac{dy}{dx} + 2\frac{dz}{dx} + 3y + z &= e^{2x} \\ \frac{d^2y}{dx^2} - 3\frac{dy}{dx} + \frac{dz}{dx} + 2y - z &= 0.\end{aligned}$$

Is it possible to have a solution to these equations for which $y = z = 0$ when $x = 0$?

15. When a varying couple $I \cos nt$ is applied to a torsional pendulum with natural period $2\pi/m$ and the moment of inertia I , the angle of the pendulum satisfies the equation of motion $\ddot{\theta} + m^2\theta = \cos nt$. The couple is first applied at $t = 0$ when the pendulum is at rest in equilibrium. Show that in the subsequent motion the root mean square angular displacement is $1/|m^2 - n^2|$ when the average is taken over a time large compared with $1/|m - n|$. Discuss the motion as $|m - n| \rightarrow 0$.

16. Solve the differential equation

$$\frac{d^2y}{dx^2} - 2\frac{dy}{dx} + (\beta^2 + 1)y = e^x \sin^2 x$$

for general values of the real parameter β . Explain why this solution fails for $\beta = 0$ and $\beta = 2$ and find solutions for these values of β .

MT VII

1. Consider a general two dimensional matrix with real coefficients of the form

$$\underline{G} = \begin{pmatrix} a & b \\ c & d \end{pmatrix}$$

- (i) Find the transpose \underline{G}^T .
- (ii) What are the minors and cofactors of \underline{G} ?
- (iii) Calculate the determinant of \underline{G} .
- (iv) Under which condition on the coefficients can \underline{G} be inverted?
- (v) Calculate the inverse of \underline{G} .
- (vi) What is the trace of \underline{G} ?

2. By showing that

$$D = \begin{vmatrix} 4 & 3 & 0 & 1 \\ 9 & 7 & 2 & 3 \\ 4 & 0 & 2 & 1 \\ 3 & -1 & 4 & 0 \end{vmatrix} = \begin{vmatrix} 4 & 3 & 0 & 1 \\ -3 & 1 & 0 & 0 \\ 0 & -3 & 2 & 0 \\ 3 & -1 & 4 & 0 \end{vmatrix},$$

evaluate the determinant.

3. Find the inverse of the matrix

$$\underline{A} = \begin{pmatrix} 1 & 2 & -1 \\ 3 & 1 & -2 \\ 1 & -1 & 1 \end{pmatrix}$$

by using the ‘matrix of cofactors’ approach. Check your result by calculating $\underline{A}\underline{A}^{-1}$.

4. The vectors \mathbf{a} , \mathbf{b} and \mathbf{c} are not coplanar. Show that there exists a unique *reciprocal vector* \mathbf{a}' , perpendicular to \mathbf{b} and to \mathbf{c} with $\mathbf{a} \cdot \mathbf{a}' = 1$. The vectors \mathbf{b}' and \mathbf{c}' are defined similarly. Prove that any vector \mathbf{r} can be written in the form

$$\mathbf{r} = (\mathbf{r} \cdot \mathbf{a})\mathbf{a}' + (\mathbf{r} \cdot \mathbf{b})\mathbf{b}' + (\mathbf{r} \cdot \mathbf{c})\mathbf{c}'.$$

Three planes whose normals are in the directions of the non-coplanar vectors \mathbf{l} , \mathbf{m} and \mathbf{n} pass through the points \mathbf{a} , \mathbf{b} and \mathbf{c} respectively. Find the distance from the point of intersection of these planes to the plane through the origin with unit normal \mathbf{p} .

5. Out of three vectors \mathbf{a} , \mathbf{b} and \mathbf{c} we can make a 3×3 matrix as follows:

$$\mathbf{A} \equiv \begin{pmatrix} A_{11} & A_{12} & A_{13} \\ A_{21} & A_{22} & A_{23} \\ A_{31} & A_{32} & A_{33} \end{pmatrix} \equiv \begin{pmatrix} a_1 & a_2 & a_3 \\ b_1 & b_2 & b_3 \\ c_1 & c_2 & c_3 \end{pmatrix} \equiv \begin{pmatrix} \mathbf{a} \\ \mathbf{b} \\ \mathbf{c} \end{pmatrix}.$$

Show that the determinant of \mathbf{A} is $\mathbf{a} \cdot (\mathbf{b} \times \mathbf{c})$. For any vector \mathbf{r} show that

$$\mathbf{A} \cdot \mathbf{r} = \begin{pmatrix} \mathbf{a} \cdot \mathbf{r} \\ \mathbf{b} \cdot \mathbf{r} \\ \mathbf{c} \cdot \mathbf{r} \end{pmatrix}.$$

6. Use the representation $\mathbf{r} = \alpha\mathbf{a}' + \beta\mathbf{b}' + \gamma\mathbf{c}'$ of \mathbf{r} in terms of the reciprocal vectors to show that if $\mathbf{A} \cdot \mathbf{r} = \mathbf{d}$, then

$$\mathbf{r} = \frac{1}{|\mathbf{A}|} (d_1 \mathbf{b} \times \mathbf{c} + d_2 \mathbf{c} \times \mathbf{a} + d_3 \mathbf{a} \times \mathbf{b}).$$

7. Show that inverse of \mathbf{A} is

$$\mathbf{A}^{-1} \equiv \frac{1}{|\mathbf{A}|} \begin{pmatrix} (\mathbf{b} \times \mathbf{c})_1 & (\mathbf{c} \times \mathbf{a})_1 & (\mathbf{a} \times \mathbf{b})_1 \\ (\mathbf{b} \times \mathbf{c})_2 & (\mathbf{c} \times \mathbf{a})_2 & (\mathbf{a} \times \mathbf{b})_2 \\ (\mathbf{b} \times \mathbf{c})_3 & (\mathbf{c} \times \mathbf{a})_3 & (\mathbf{a} \times \mathbf{b})_3 \end{pmatrix},$$

by showing that $\mathbf{r} = \mathbf{A}^{-1} \cdot \mathbf{d}$.

8. Given the matrices

$$\underline{A} = \begin{pmatrix} 0 & 1 \\ -1 & 0 \end{pmatrix}, \quad \underline{B} = \begin{pmatrix} 3 & 4 & 2 \\ 6 & 1 & 2 \\ 1 & 3 & 4 \end{pmatrix}, \quad \underline{C} = \begin{pmatrix} 1 & 1 & 3 \\ 3 & 2 & 2 \end{pmatrix}$$

$$\underline{D} = \begin{pmatrix} 2 & 1 \\ 3 & 1 \end{pmatrix}, \quad \underline{a} = \begin{pmatrix} 1 \\ 1 \end{pmatrix}, \quad \underline{c} = \begin{pmatrix} 2 \\ 1 \\ 2 \end{pmatrix}, \quad \underline{d}^T = (4 \ 2 \ 1)$$

Calculate the following if possible:

- (i) $\underline{A} \cdot \underline{A}$, $\underline{A} + \underline{B}$, $\underline{D} - \underline{A}$, $\underline{A} \cdot \underline{C}$.
- (ii) $\underline{C} \cdot \underline{B}$, $\underline{B} \cdot \underline{C}$, $\underline{A} \cdot \underline{a}$, $\underline{d}^T \cdot \underline{B} \cdot \underline{c}$.
- (iii) Calculate $\underline{A} \cdot \underline{D}$ and $\underline{D} \cdot \underline{A}$ and observe that matrix multiplication is not commutative in general.

Linear equations

9. Solve the system of linear equations $x - 3y = 2$ and $-2x + 6y = a$ for \mathbf{r} for $a = 1$ and $a = -4$ and give a geometrical interpretation of the solution.

10. Solve the system of linear equations $-2x + 4y - 2z = -1$ and $3x + 2y + 4z = -5$ and give a geometric interpretation.

11. Solve the system of linear equations $x + 4y - 2z = 1$, $x - y + 2z = 2$ and $3x - 2y + 4z = -5$ and give a geometric interpretation.

12. For what value of β do the equations

$$\begin{aligned}x + y + z &= 0 \\x + \beta y &= s \\2x + 2y + z &= 3\end{aligned}$$

have a unique solution? For what values of β and s are the equations inconsistent? For the special case $\beta = 1$ and $s = 3$ obtain the solution in the form of the vector equation of a line. Illustrate your answer with a sketch.

13. What condition has to be satisfied by $\det(\underline{A})$ for the homogeneous equation $\underline{A} \cdot \mathbf{r} = 0$ to have a nontrivial solution? Show that this condition is satisfied for the equations

$$\begin{aligned}2x + 3z &= 0 \\4x + 2y + 5z &= 0 \\x - y + 2z &= 0\end{aligned}$$

and find the solution in the form of a line.

14. Using the row reduction method, find the inverses of the matrices

$$\underline{A} = \begin{pmatrix} 1 & 2 & -1 \\ 3 & 1 & -2 \\ 1 & -1 & 1 \end{pmatrix} \quad \text{and} \quad \underline{B} = \begin{pmatrix} 2 & -2 & 1 \\ 3 & 1 & -4 \\ 5 & -3 & 2 \end{pmatrix}$$

15. Find the ranks of the matrices

$$\underline{A} = \begin{pmatrix} 1 & 4 & -5 \\ 5 & 2 & 1 \\ 2 & -1 & 3 \\ 3 & -6 & 11 \end{pmatrix} \quad \text{and} \quad \underline{B} = \begin{pmatrix} 1 & 2 & 0 \\ 1 & 2 & 1 \\ 2 & 4 & 1 \\ 0 & 0 & 1 \end{pmatrix}.$$

16*. A is the point $(3, -1, 2)$. The line

$$\frac{x-3}{2} = \frac{y+1}{1} = \frac{z-2}{-1}$$

meets the plane $2x + 3y + z + 1 = 0$ at the point B. The line BC lies in this plane and is perpendicular to AB. Find (i) the coordinates of B; (ii) the equation of the plane through B perpendicular to AB; (iii) the equations of the line BC; (iv) the equation of the plane through AB and BC.

17*. Find the equation of the plane P through the line

$$\frac{x-3}{2} = \frac{y-4}{2} = \frac{z-5}{-1}$$

which is parallel to the line $x = y = z$; and also the equation of the plane through the first line which is perpendicular to P. Hence find the equation of the line which cuts both lines at right angles.

MT VIII

Vectors

1. A particle of unit mass is acted on by a constant force represented by the vector \mathbf{a} and by a retarding force proportional to its velocity. The equation of motion is

$$\frac{d^2\mathbf{r}}{dt^2} = a - \gamma \frac{d\mathbf{r}}{dt}$$

where $\gamma > 0$ is a constant. At time $t = 0$ $\mathbf{r} = \mathbf{r}_0$ and $d\mathbf{r}/dt = \mathbf{v}_0$.

(i) Show that $d[\mathbf{a} \wedge (\gamma\mathbf{r} + d\mathbf{r}/dt)]/dt = 0$.

(ii) Find the differential equation satisfied by $s = \mathbf{a} \cdot \mathbf{r}$ and solve it.

(iii) Sketch s and ds/dt as a function of time t for the case $\mathbf{r}_0 = 0$ and $\mathbf{a} \cdot \mathbf{v}_0 = 0$.

2. \mathbf{a} is a vector depending on time t , and $\boldsymbol{\Omega}$ is a constant vector. The vector \mathbf{a} obeys the equation of motion $d\mathbf{a}/dt = \boldsymbol{\omega} \wedge \mathbf{a}$.

(i) Show that $\mathbf{a} \cdot d\mathbf{a}/dt = 0$. Write down, in words, what this equation implies about the motion of \mathbf{a} .

(ii) Show that $d\mathbf{a}^2/dt = 0$, and that $d(\mathbf{a} \cdot \boldsymbol{\Omega})/dt = 0$. What do these equations tell us about the motion of \mathbf{a} .

(iii) On the basis of the information provided by the points (i) and (ii), sketch a possible motion of \mathbf{a} .

(iv) How many initial conditions are required to get a unique solution for \mathbf{a} ?

(v) Now consider the particular case $\boldsymbol{\Omega} = \Omega\mathbf{k}$ and $\mathbf{a} = a_x\mathbf{i} + a_y\mathbf{j} + a_z\mathbf{k}$. Show that $\dot{a}_x = -\Omega a_y$, $\dot{a}_y = \Omega a_x$, and $\dot{a}_z = 0$. Find $\mathbf{a}(t)$ for $\mathbf{a}(0) = (1, 1, 1)$ and describe the motion of $\mathbf{a}(t)$ as time varies.

3*. Consider a vector \mathbf{v} in 2D and rotate it anticlockwise by an angle α . The resulting vector is given by $R_\alpha(\mathbf{v})$. Show that the rotation is a linear function. Now rotate the vector further by an angle β and find that $R_\beta(R_\alpha(\mathbf{v})) = R_{\alpha+\beta}(\mathbf{v})$.

4*. Consider the above 2D rotation in 3D where it corresponds to a rotation around the z -axis in direction $\mathbf{n} = (0, 0, 1)$ and $\mathbf{v} = (v_x, v_y, 0)$. Show that the rotated vector is given by $\cos(\alpha)\mathbf{v} + \sin(\alpha)\mathbf{n} \wedge \mathbf{v}$.

5*. How is the component of a vector parallel to the axis of rotation in 3D changed during the rotation? With the result of problem 2 conclude that rotating a vector \mathbf{v} around an axis \mathbf{n} by an angle α yields a vector found by the linear function $R_\alpha^n(\mathbf{v})$

$$R_\alpha^n(\mathbf{v}) = \mathbf{n}(\mathbf{n} \cdot \mathbf{v})(1 - \cos(\alpha)) + \cos(\alpha)\mathbf{v} + \sin(\alpha)\mathbf{n} \wedge \mathbf{v}.$$

6*. A sphere with center \mathbf{r}_0 and radius R is defined as the set of all points \mathbf{r} with $(\mathbf{r} - \mathbf{r}_0) \cdot (\mathbf{r} - \mathbf{r}_0) = R^2$. Calculate values for \mathbf{r}_0 and R such that the points $\mathbf{a} = (1, 0, 2)$, $\mathbf{b} = (0, 1, 2)$, and $\mathbf{c} = (2, 2, 3)$ lie on the sphere. Find in particular the sphere with $x_0 = 1$. Discuss how the number of different possible solutions for the center and the radius of the sphere depends on the choice of the vectors $\mathbf{a}, \mathbf{b}, \mathbf{c}$.

7*. Find the variable x from the condition

$$\begin{vmatrix} 1 & x & x^2 \\ x & x^2 & 1 \\ x^2 & 1 & x \end{vmatrix} = 0$$

Show that $1 + x + x^2$ is a factor of the determinant (hint: try adding the three rows together). Show that the solutions for x are $x = 1, -1/2 \pm i\sqrt{3}/2$.

ODEs

8. Verify that $y = x + 1$ is a solution of

$$(x^2 - 1) \frac{d^2 y}{dx^2} + (x + 1) \frac{dy}{dx} - y = 0.$$

Writing $y = (x + 1)u$, show that $u' = du/dx$ satisfies

$$\frac{du'}{dx} + \frac{3x - 1}{x^2 - 1} u' = 0.$$

Hence show that the general solution of the original equation is

$$y = K \left(\frac{1}{4}(x + 1) \ln \frac{x - 1}{x + 1} - \frac{1}{2} \right) + K'(x + 1),$$

where K and K' are arbitrary constants.

9. Find a continuous solution with continuous first derivative of the system

$$\frac{d^2 y}{dx^2} + 2 \frac{dy}{dx} + 2y = \sin x + f(x)$$

subject to $y(-\frac{1}{2}\pi) = y(\pi) = 0$, where

$$f(x) = \begin{cases} 0 & x \leq 0 \\ x^2 & x > 0 \end{cases}.$$

[Hint: obtain a general solution for each of the cases $x < 0$ and $x > 0$ and then obtain relations between your four arbitrary constants by making the solutions agree at $x = 0$.]

10. An alternating voltage $V = V_0 \sin \omega t$ is applied to the circuit below.

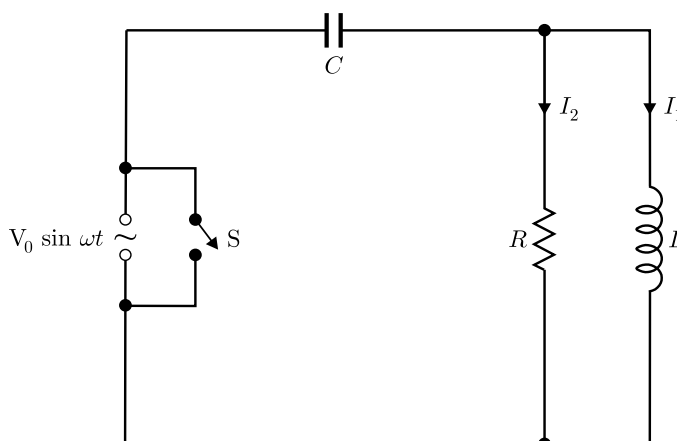

The following equations may be derived from Kirchhoff's laws:

$$I_2 R + \frac{Q}{C} = V,$$

$$L \frac{dI_1}{dt} = I_2 R,$$

$$\frac{dQ}{dt} = I_1 + I_2,$$

where Q is the charge on the capacitor.

Derive a second-order differential equation for I_1 , and hence obtain the steady state solution for I_1 after transients have decayed away.

Determine the angular frequency ω at which I_1 is in phase with V , and obtain expressions for the amplitudes of I_1 and I_2 at this frequency.

Suppose now that the switch S is closed and the voltage supply removed when I_1 is at its maximum value. Obtain the solution for the subsequent variation of I_1 with time for the case $L = 4CR^2$, and sketch the form of your solution.

11*. Spherical polar coordinates (r, θ, ϕ) are defined in terms of Cartesian coordinates (x, y, z) by

$$x = r \sin \theta \cos \phi, \quad y = r \sin \theta \sin \phi, \quad z = r \cos \theta.$$

(a) Find $(\partial x / \partial r)$, treating x as a function of the spherical polar coordinates, and $(\partial r / \partial x)$ treating r as a function of the Cartesian coordinates.

(b) Given that f is a function of r only, independent of θ and ϕ , show that

$$\frac{\partial f}{\partial x} = \frac{x}{r} \frac{df}{dr},$$

$$\frac{\partial^2 f}{\partial x^2} = \frac{1}{r} \frac{df}{dr} + \frac{x^2}{r} \frac{d}{dr} \left(\frac{1}{r} \frac{df}{dr} \right),$$

and hence deduce that

$$\frac{\partial^2 f}{\partial x^2} + \frac{\partial^2 f}{\partial y^2} + \frac{\partial^2 f}{\partial z^2} = \frac{1}{r^2} \frac{d}{dr} \left(r^2 \frac{df}{dr} \right).$$